



Product Specification

Central Diesel provides these specifications as a courtesy and are a guide only. They have been sourced from the manufacturer and may change without notice. Central Diesel accepts no responsibility for any errors or omissions.

Introducing the SCPB Series

High performance - low noise - energy efficient



- Single Stage Centrifugal Pump
- Fully wet-tested with a 2 year warranty
- 2" inlet/outlet for higher performance & lower noise
- 316 stainless steel shaft
- Thermal overload protector
- Liquid temperature from +5°C ~ +60°C
- Ambient temperature up to 50°C
- Max working pressure 2.5 bar
- Mechanical seal SB-16 is made by carbon/ceramic/EPDM

Motor

2-pole induction motor
Single phase: 220-240V/ 50Hz
Single phase with thermal protector
Capacitor inset
IPX5 Protection
Continuous Duty

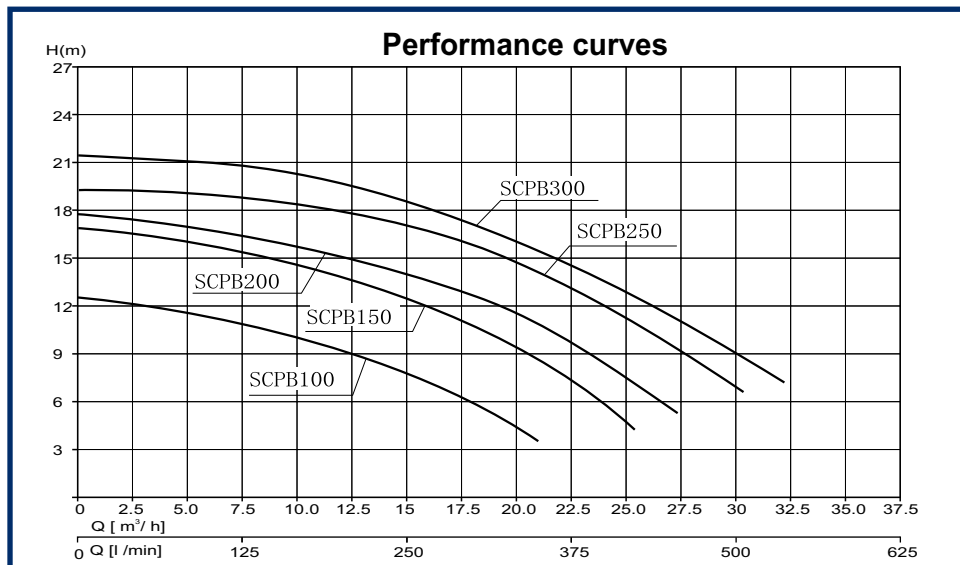
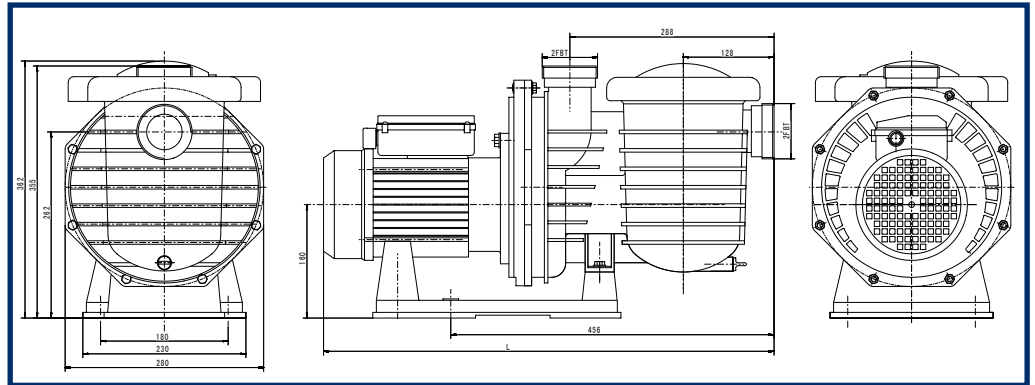

INTRODUCTORY PRICES 10% OFF WHOLESALE PRICE

UP-SCP B100-1	\$216.00
UP-SCP B150-1	\$230.00
UP-SCP B200-1	\$260.00
UP-SCP B300-3	\$293.00

Prices quoted ex GST / ex freight
Prices valid until 30th November 2009



1300 132 302

water@adgglobalsupply.com
www.adgglobalsupply.com

To take advantage of this introductory price contact your account manager now!

PHONE: 1300 132 302